



Item No.: NT9004

Description: Pedal Off-Road Hunter

Dimension: 870(L) x 400(W) x 585(H) mm

34.25(L) x 15.75(W) x 23.03(H) inch

Carton Size: 920(L) x 420(W) x 390(H) mm \approx 0.1507 m³

36.22(L) x 16.54(W) x 15.35(H) inch \approx 5.32 ft³

Net Weight: 10.5 KGS

Carrying Weight: 50 KGS

Case Pack: 1 PC per CTN

Age: 3+

Container Loading Quantity

20'GP: 190 PCS

40'HQ: 450 PCS

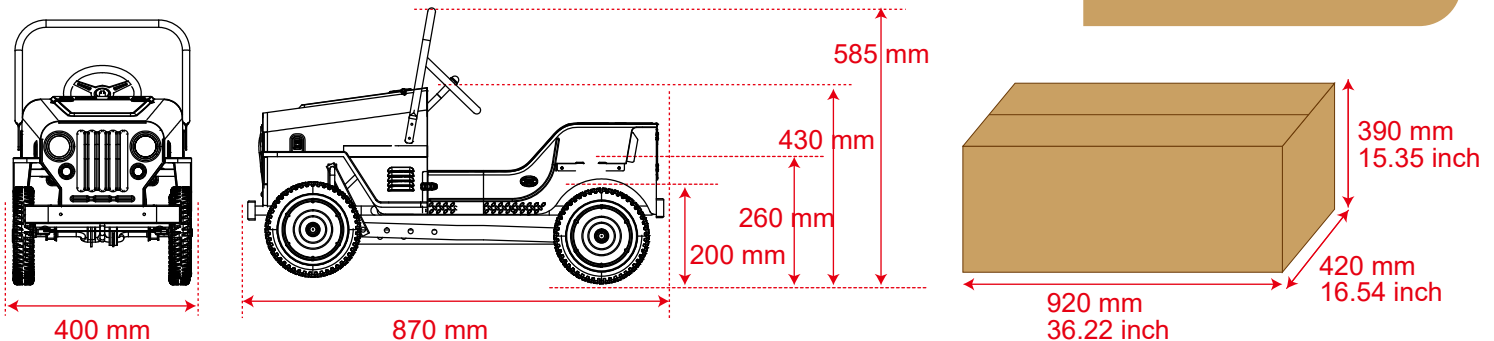

More Models



NT9004050



NT9003010



NT9003040



NT9003160

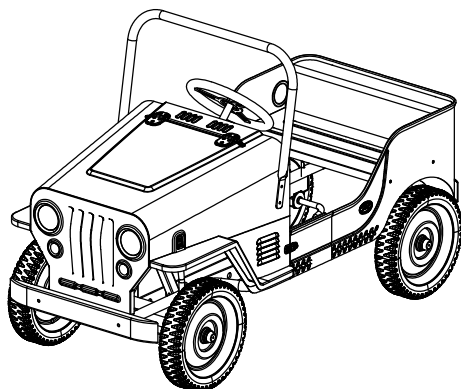

**Customised Designs
Are Welcome**