



Item No.: NT8101

Description: Kids Steel Ride-On Excavator

Dimension: 980(L) x 260(W) x 560(H) mm

38.58(L) x 10.24(W) x 22.05(H) inch

Carton Size: 400(L) x 290(W) x 225(H) mm  $\approx$  0.0261 m<sup>3</sup>

15.75(L) x 11.42(W) x 8.86(H) inch  $\approx$  0.92 ft<sup>3</sup>

Net Weight: 4.0 KGS

Carrying Weight: 35 KGS

Case Pack: 1 PC per CTN

Age: 3+

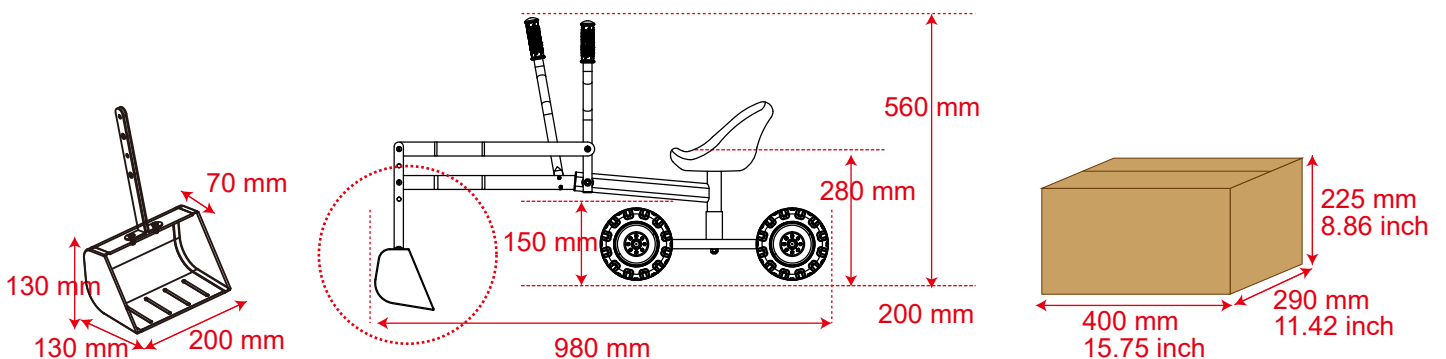

# Available Models



NT8101030



NT8101031

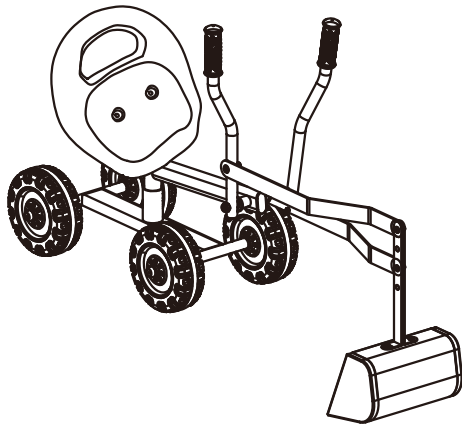

**Customised Designs  
Are Welcome**

## More Related



NT6001010



NT6001030



NT6001040



NT6001070



NT6001140



NT7001010



NT7001030



NT7001040